



UDK: 661.847.371.1

**Rustamjon K. ERMATOV,**

*PhD student, Namangan State Technical University*

*E-mail:ermatovrustamjon0797@gmail.com ORCID 0009-0002-9047-4922*

**G‘olibjon A. DOLIYEV,**

*Professor of the Department of Chemistry, Namangan State University, DSc*

**Sobirjon B. MAMAJANOV,**

*Associate professor of chemistry department, Namangan State University, PhD*

**Nazira K. CHINIBEKOVA,**

*Associate professor of the department of organic synthesis, Tashkent pharmaceutical institute*

*NamDTU Professori, t.f.d Z.To‘rayev taqrizi asosida*

### PERFORMANCE EVALUATION OF WELDING ELECTRODES PRODUCED FROM INDIGENOUS MATERIALS

Annotation

This article presents the types of steel wires and the activity of surface tension on their surfaces, as well as technologies for producing welding electrode components based on local raw materials. In addition, the temperature-dependent conditions of a new sample obtained from local raw materials were studied and compared with analogues in terms of quality and efficiency.

**Key words:** electrode, sand, dolomite, kaolin, rutile, titanium (II) oxide, ferromagnets, marmalade powder, ferrotitanium, starch, feldspar.

### ОЦЕНКА ЭКСПЛУАТАЦИОННЫХ ХАРАКТЕРИСТИК ЭЛЕКТРОДОВ ДЛЯ СВАРКИ, ИЗГОТОВЛЕННЫХ ИЗ МЕСТНЫХ МАТЕРИАЛОВ"

Аннотация

В статье рассмотрены виды стальных проволок и влияние поверхностного натяжения на их свойства. Разработана технология получения компонентов покрытия сварочных электродов на основе местного сырья. Изучены температурные характеристики нового образца и проведено сравнение с промышленными аналогами по качеству и эффективности.

**Ключевые слова:** сварочный электрод, стальная проволока, местное сырьё, рутил, оксид титана, ферромарганец, ферротитан.

### MAHALLIY XOM ASHYO ASOSIDA ISHLAB CHIQRILGAN PAYVANDLASH ELEKTRODLARINING ISHLASH SAMARADORLIGINI BAHOLASH

Annotatsiya

Maqolada po‘lat sim turlari hamda sirt tarangligining ularning xususiyatlariga ta‘siri ko‘rib chiqilgan. Mahalliy xom ashyo asosida payvandlash elektrodi qoplamlarini olish texnologiyasi ishlab chiqilgan. Yangi namunaning haroratga bog‘liq xususiyatlari o‘rganilib, mavjud analoglar bilan sifat va samaradorlik jihatidan taqqoslangan.

**Kalit so‘zlar:** payvandlash elektrodi, po‘lat sim, mahalliy xom ashyo, rutil, titan oksidi, ferromarganes, ferrotitan.

**Introduction.** In recent years, the production range of welding electrodes has significantly expanded, increasing their competitiveness in the global market. Ensuring high quality, durability, and long service life of welded structures remains one of the key objectives in modern welding technology. Worldwide research efforts are focused on developing energy-efficient and resource-saving production methods to improve welding performance.

Despite this progress, electrode coatings are still largely manufactured using costly imported raw materials. Limited scientific research on the complex use of local mineral resources and on optimizing weld metal properties has restricted the development of domestically produced coated electrodes. Establishing a scientifically grounded approach to selecting and combining coating components is essential for achieving stable physicochemical and mechanical characteristics of weld metal.

In Uzbekistan, the rapid growth of metal-processing industries has led to increased demand for welding consumables. Currently, approximately 30 thousand tons of electrodes are imported annually, mainly from foreign suppliers. However, the availability of domestic mineral resources creates favorable conditions for producing competitive electrodes based on local raw materials. The implementation of such technologies not only reduces dependence on imports and saves foreign currency, but also ensures environmentally sustainable production with performance characteristics comparable to existing analogues.

**Literature review.** Scientific sources indicate that steel wires made of carbon and alloyed steels serve as the principal raw materials for welding electrodes. Depending on carbon content, structural welding electrodes are classified into low-carbon, medium-carbon, and high-carbon types, each differing in weldability and mechanical performance. Low-carbon steels (up to 0.22% C) demonstrate good weldability without significant hardening, while medium- and high-carbon steels require controlled thermal regimes to prevent cracking and structural brittleness.

Researchers emphasize that weldability is a complex metallurgical property influenced by chemical composition, microstructure, and welding parameters. Steels used for welding applications are generally categorized into pearlitic, bainitic, martensitic, ferritic, and austenitic classes. For general-purpose electrodes, pearlitic steels are most common, whereas specialized electrodes employ alloyed steels with improved mechanical and operational characteristics.

The literature also highlights the importance of heat-affected zone (HAZ) behavior, particularly in thermally hardened steels, where improper thermal cycles may reduce strength and cause structural transformations. To prevent defects such as cracking and embrittlement, preheating, post-weld heat treatment, and appropriate electrode selection are recommended. Electrode grades (e.g., E38, E42, E46) are selected according to service load conditions and base metal composition.

In addition, studies on contact and spot welding of steel wires describe the formation of metallurgical bonds through short-duration electric current and compressive force. The welding process typically occurs in four stages: surface preparation, heating and plastic deformation, molten nugget formation, and solidification. Proper control of current, pressure, and temperature ensures uniform weld structure and minimizes inclusions or defects.

Overall, previous research confirms that electrode performance and weld quality are determined by the combined influence of steel composition, microstructural class, thermal regime, and welding technology, which necessitates a scientifically grounded approach in electrode development.

**Research Methodology.**

Based on the results of the conducted laboratory studies and pilot trials, the material flow for obtaining electrode coatings and welding electrodes from locally sourced raw materials was calculated, and a principal technological scheme was proposed.

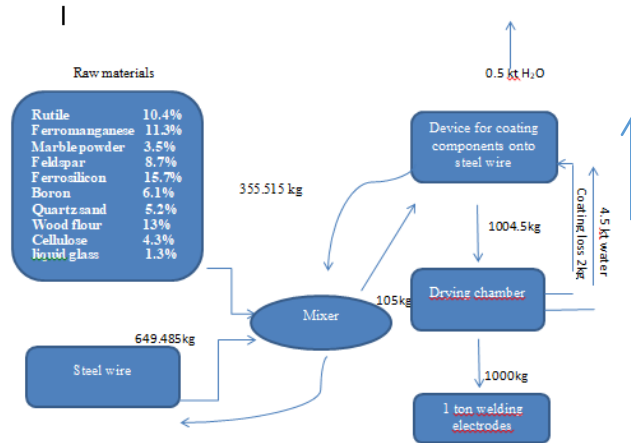

**Figure 1. Material flow of welding electrode coatings and electrode production.**

The purpose of this study was to develop a new technological scheme for producing a dry lubricating composite and welding electrodes based on locally sourced raw materials, to conduct laboratory and industrial trials, and to evaluate their technical and economic efficiency. The research was carried out systematically in both laboratory and industrial environments.

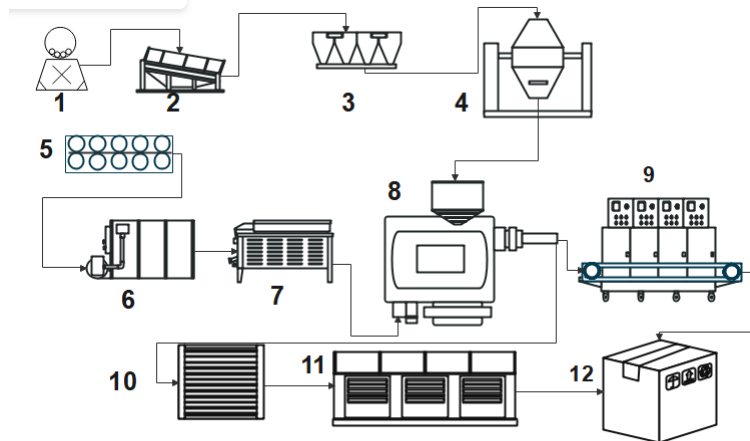

**Figure 2. New technological scheme for the production of welding electrodes based on local raw materials.**

**Analysis and results.** The research was conducted in a systematic and integrated manner under both laboratory and industrial conditions. Initially, a dry lubricating composite was synthesized using a newly developed technological approach based on local raw materials. Laboratory investigations were carried out to determine key physicochemical and technological parameters, including total grease (fatty) content, alkalinity, moisture content, adhesion capacity to the metal surface, consumption rate, residue amount, and recyclability. Particular attention was given to optimizing the content of the main lubricating components - calcium and sodium salts of higher fatty acids - since insufficient or excessive amounts could negatively affect the surface quality of drawn steel wire and lead to technological defects. Based on analytical evaluation of laboratory results, the optimal composition was selected for industrial pilot testing.

Industrial trials were conducted at steel wire drawing enterprises in Namangan city, where the developed composite was applied in the dry drawing process. In this process, the steel wire passes through the lubricating composite, then through a die, resulting in a gradual reduction of diameter and subsequent winding onto a drum. During testing, surface quality of the wire, friction behavior, process stability, composite consumption, and overall technological reliability were assessed. In parallel, welding electrodes manufactured using the newly developed composite were tested in a production workshop operating under a closed

technological cycle equipped with modern Swiss machinery and advanced laboratory and research instruments. Comparative evaluation confirmed that the proposed product does not fall behind imported analogues in terms of quality while offering competitive pricing due to the use of local raw materials.

The economic efficiency assessment included analysis of import prices (USD 3,800 per ton from China and USD 4,000 per ton from Russia), estimation of local production costs (USD 1,500–1,650 per ton), and evaluation of domestic demand. In Namangan region, six wire-drawing enterprises consume approximately 200 kg per month each, contributing to a total annual demand of 172.8 tons across the Republic. Comparative calculations showed an average saving of USD 750 per ton. With a planned production capacity of 10,000 tons per year, total annual savings could reach USD 7.5 million. Considering that approximately 180,000 tons of lubricating composite are imported annually, implementation of the proposed technology would significantly contribute to import substitution, foreign currency savings, and the creation of new employment opportunities.

Table 1

Economic efficiency of domestic and imported electrodes

Welding electrode	The cost of the electrode (1 set - 100 pieces)				
	Raw material mas	China	Russia	Local	Efficiency is average
2 mm	600 g	9300 soum	10300 soum	5200 soum	4600 soum
3 mm	850 g	13200 soum	14600 soum	7200 soum	6700 soum
4 mm	1400 g	21700 soum	24000 soum	12000 soum	10850 soum
	1 ton	15500000 soum	17167000 soum	8667000 soum	7 666 500 soum

According to customs data, in 2020–2021 the production of welding electrodes based on localized raw materials in Namangan region is expected to replace imported products, resulting in average annual savings of approximately USD 400,000 in the region and about USD 5.3 million nationwide, while also contributing to the creation of new jobs.

**Conclusion.** The conducted research confirms the scientific, technological, and economic feasibility of producing dry lubricating composites and welding electrodes based on locally sourced raw materials. The developed technological scheme ensures stable physicochemical properties, optimal lubrication performance during the steel wire drawing process, and high surface quality of the finished product. Laboratory investigations and industrial pilot trials demonstrated that the proposed composite meets technological requirements and does not уступ imported analogues in terms of operational characteristics.

Industrial validation proved that the integration of the developed composite into existing production lines is technically viable and compatible with modern equipment operating under a closed technological cycle. The optimization of calcium and sodium salts of higher fatty acids in the composition ensured process stability, reduced friction-related defects, and improved overall production efficiency. Economic analysis revealed significant cost advantages of local production compared to imported materials. The lower production cost per ton provides substantial savings at both regional and national levels. The projected annual savings, including up to USD 7.5 million at planned production capacity and USD 5.3 million in nationwide import substitution based on customs data, highlight the strategic importance of implementing this technology. In addition to foreign currency savings, the project contributes to industrial localization, strengthens domestic manufacturing capacity, and creates new employment opportunities.

Overall, the research outcomes demonstrate that the developed technology represents an effective solution for import substitution in the metallurgical sector, ensuring competitive product quality, economic efficiency, and sustainable industrial development.

#### REFERENCES

- Siddikov M.Kh., Sadullayev N.R. Research on the use of industrial waste phosphogypsum as a building gypsum and increasing its strength Proceedings of International Conference on Educational Discoveries and Humanities 2023, pp. 138-144 file:///C:/Users/AORUS/Downloads/27%20(13).pdf
- Крампит Н.Ю., Крампит М.А. Импульсно-дуговая сварка с подогревом вылета пайвандлаш электрода в паузе // Сварочное производство. – 2014. – №3. – С. 8-10.
- Crespo A.C. A. Scotti; M.R. Pirez. Operacional Behaviour Assesment of Coated Tubular Electrodes for SMAW Hardfacing // Journal of Materials Processing Tech Nology. Elsevier Science Publ. Holland. №. 199. 2008. pp. 265-273.
- Brady G.S. Materials handbook: a encyclopaedia managers. technical professionals. purchasing and production managers. technicians and supervisors // McGraw Hill. New York 1997. p. 350.
- S.Khudoyorov, N. Dunyashin Mineral resources of the Republic of Uzbekistan for the production of fused fluxes for automatic arc welding. International Journal of Advanced Research in Science // Engineering and Technology Vol. 7, Issue 5, May 2020 pp1359-1360.
- Ғ.А.Долиев, А.Абдулхаев, И.Ғофуров, Х.Эргашева, Г.Сайдуллаева Импорт ва маҳаллий пайвандлаш электродини ИК ва элемент анализ таҳлили // НамДУ илмий ахборотномаси - Научный вестник НамГУ 2022 йил 4 сон 116-17 бет.